

Air Handling Units - External (EME/EC) Installation, Operation and Maintenance Manual

Introduction

Designed for external applications, the EME/EC range encompasses 5 models of direct driven centrifugal air handling units with airflow duties up to 0.6m³/s.

Motor windings are fitted with an auto-reset thermal cut-out.

Motors are pre-wired to an external terminal box trickle – boost speed controller and isolator.

Units complete with integral G3 panel filter and electric heater battery.

General Construction

Casework is manufactured from 0.9mm to 1.6mm thick powder-coated (BS10A05 as standard - other colours on request) galvanised sheet steel with an 'O' class foam / barrier mat sandwich insulation to provide acoustic insulation.

Access is via removable top cover.

Inlet via bird-mesh protected cowl

Inspection Upon Receipt Of Goods

Immediately upon receipt of any goods, a careful inspection should be undertaken to ensure neither damage nor missing parts. Particular attention should be paid to the fan impeller and casework.

In the event of such damage or loss having occurred, inform AVT (01264 356415) WITHIN 3 WORKING DAYS of the delivery date, giving the serial number which can be found on the name-plate. After this period we will be unable to entertain any claim for loss or damage.

Handling

Units must be handled with care to avoid damage, particularly units being craned into position. Attention must be paid to the overhanging weather lid and plastic finish.. A spreader bar should be employed to prevent damage to the top of the unit.

Installation

When installing our equipment, the following must be observed:

Safety: It is the responsibility of the installer to ensure that the installation complies with the legal regulations and the current HEALTH AND SAFETY AT WORK ACT.

Ambient Temperatures: The range of units covered by this manual are designed for use in an environment where the ambient air temperature is unlikely to exceed 40°C.

Mounting / Positioning: These units must be mounted in the horizontal plane and on a completely flat base. EME/EC units have integral mounting feet.

Duct Connections: Adjoining ductwork should always be independently supported to avoid undue stress on the unit casing. Impellers are statically and dynamically balanced, and anti-vibration mounts and fast clamps are available to suit.

Access: All units are designed with easily removable components for maintenance purposes. Sufficient room should be allowed adjacent to the unit to allow components to be withdrawn.

Electrical Wiring

Electrical supply must be fully isolated before attempting any work on the unit.

All wiring should be carried out by a competent electrician and should comply fully with the current I.E.E. Wiring Regulations.

The electrical supply must be as stated on the nameplate.

When the wiring is complete, check for free and correct rotation of the fan impeller

Maintenance

3 Monthly: Filters should be inspected and if found to be heavily soiled, replaced.

6 Monthly: The fan impeller should be carefully cleaned with a brush. This will prevent the impeller from becoming unduly dirty and unbalanced.

12 Monthly: The security and integrity of all fastenings should be checked, particularly the motor mounting frame.

	Motor Power	Phase	FLC
EME12EC	52 W	1 ph	0.40 A
EME15EC	52 W	1 ph	0.40 A
EME20EC	70 W	1 ph	0.55 A
EME25EC	170 W	1 ph	1.40 A
EME31EC	510 W	1 ph	3.10 A

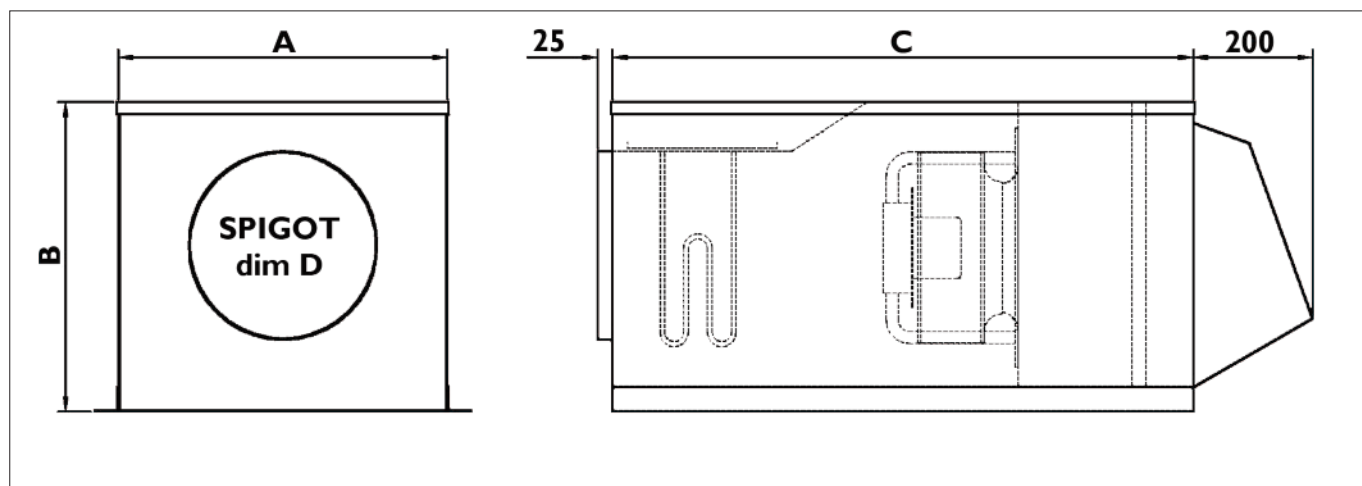

COMPACT AHUs - EXTERNAL - EHB					
Model	A	B	C	D	kg
EME12EC	400	350	750	125	24
EME15EC	400	350	750	150	24
EME20EC	425	375	850	200	35
EME25EC	650	450	900	250	43
EME31EC	650	475	900	315	47

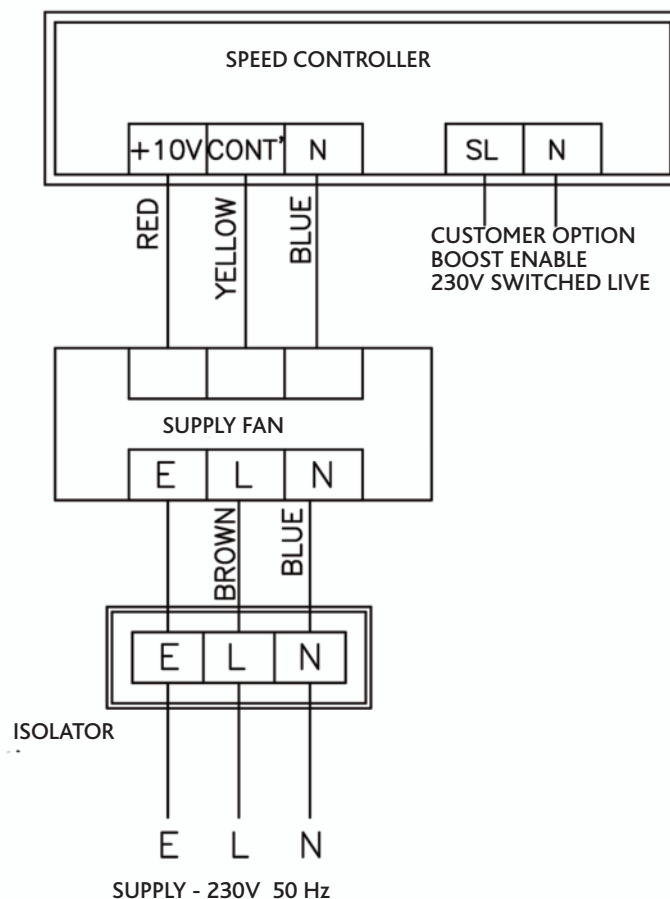

Electric Heater Battery

Introduction

Heaters of the sheathed element type provide a safe means of heating using electricity. The surface temperature of the elements is relatively low and they will not give an electric shock.

Heaters are suitable for either horizontal or vertical air-flow, though care should be taken to ensure the cutout is near the top of the duct.

An even flow of air across the elements **MUST** be maintained and the velocity should not fall below 1.75m/s. The heater should be positioned away from materials that may be damaged by direct heat.

Controls

A suitable control system should be installed which must include a timer to **keep the fan running for a period of 2 minutes after the heater has been switched off.**

A range of compatible control panels is available from AVT.

If a speed controller is being fitted, it **MUST NOT** allow the fan to be turned off independently of the control panel nor must it allow the air volume to **FALL BELOW** that stated on the heater nameplate.

Testing

Elements are tested prior to dispatch and are within a tolerance of +7.5W.

Elements stored in damp conditions may require drying out in order to achieve the correct insulation levels. Contact AVT in case of uncertainty.

Wiring Instructions

1. The electrical supply to the heater should be either 1ph or 3ph (with separate neutrals) - refer to nameplate for clarification.
2. Electrical cables should be of a high temperature, insulated type (i.e. silicone rubber or fibreglass) and be installed in accordance with current IEE wiring regulations.
3. The heater is fitted with a manual reset, thermal overload which will break the contacts when the duct temperature exceeds 130°C. This should be wired in series with the operating coil of the control circuit.
4. Ensure a suitable earth connection is made to the terminal provided.
5. The element studs are fitted with terminal pillars and care should be taken not to over tighten and cause damage to the elements.
6. Always fit an isolator for maintenance of the heater.

Component Layout

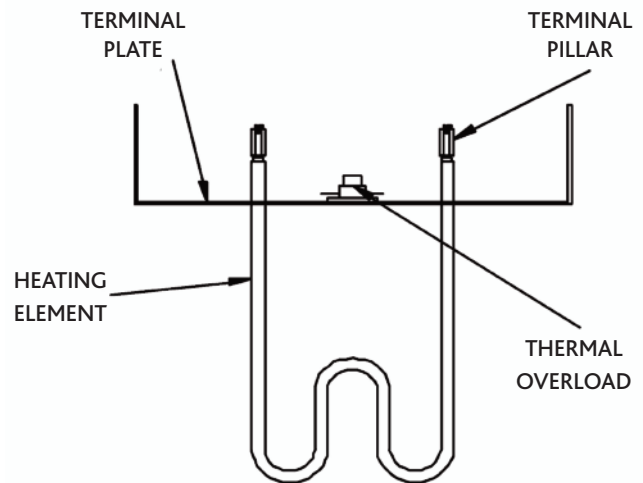

ELECTRIC HEATERS MUST BE WIRED AND INSTALLED IN ACCORDANCE WITH THE FOLLOWING DIAGRAMS AND INSTRUCTIONS

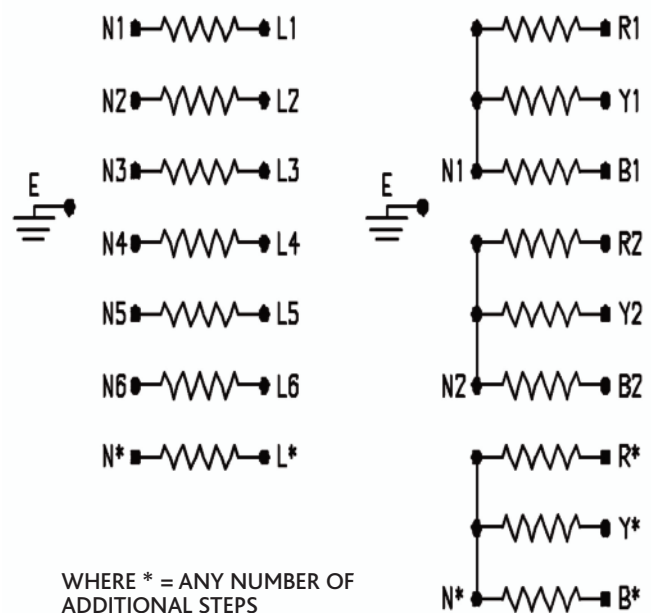

Air Vent Technology Ltd

56 Reith Way, Portway Industrial Estate

Andover, Hampshire, SP10 3TY

T: +44(0)1264 356415

E: sales@airventtechnology.co.uk

www.airventtechnology.co.uk

Part of the **Vectaire** Group of Companies